

Wandcontactdoos

Bestelnr. 1842



- schroefklemmen
- met buitenliggende bevestiging
- kabelinvoer 1 x bov en 1 x blind (breekpoort) aan de achterzijde

Technische informatie

Ampère	32 A
Polen	2 p
Voltage	50 V
Uurstand	10 h
Aansluittechniek	schroefklemmen
Contacten	standaard
Beschermingsgraad	IP 44
Gewicht	189 g
Certificeringen	EAC, CQC

Tekeningen

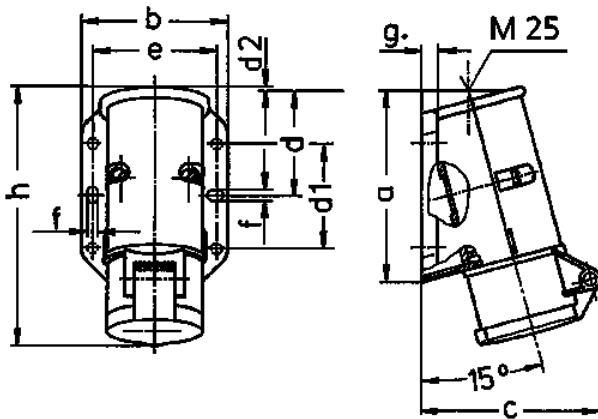

Tekening 1 MB 294	Amp. Polen	16		32	
		2	3	2	3
Maten in mm	a	96	96	96	96
	b	73	73	73	73
	c	90	90	90	90
	d	53	53	53	53
	d1	52	52	52	52
	d2	2	2	2	2
	e	62	62	62	62
	f	5,3	5,3	5,3	5,3
	g	8	8	8	8
	h	129	129	129	129
Kabelaansluiting van/tot mm ²		4	4	4	4
		-10	-10	-10	-10